

NOTES:

- ① GROUND FLAG SUPPLIED AS A KIT TO BE INSTALLED AT CUSTOMER SITE.
- ② TORQUE TO 4.18 N-M (37 IN-LBS).
- ③ REMOVE ETL STICKER FROM COLLECTOR, IF PRESENT, AND REPLACE WITH ETL STICKER IN BOM.

INSTALLATION NOTES:

- ④ WHEN INSTALLING THE GROUND INDICATOR FLAG, ORIENT THE GROUND FLAG AWAY FROM THE OTHER PHASES.
- ⑤ TORQUE TO 0.9 N-M (8 IN-LB)
- ⑥ TORQUE TO 33.9 N-M (300 IN-LB)

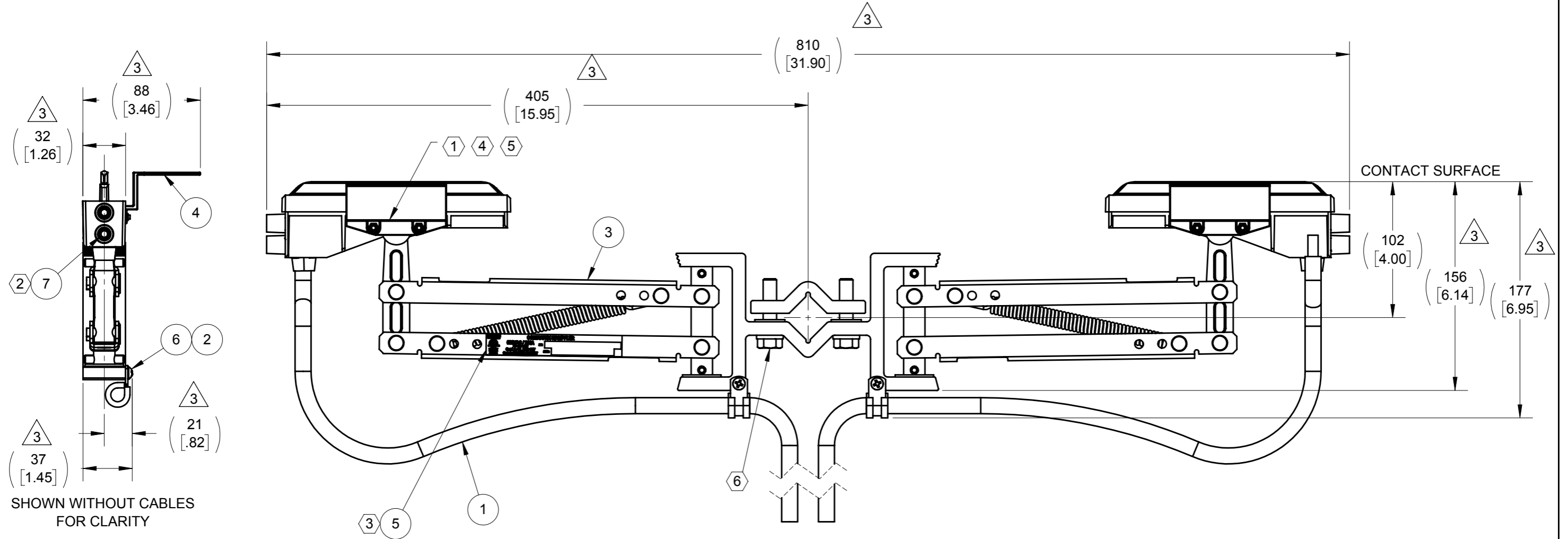

SPECIFICATIONS

COLLECTOR SETTING HEIGHT	102.0 mm	4.00"
CONTACT FORCE AT SETTING HEIGHT	20-36 N	4.5-8.0 LBS
LATERAL WORKING RANGE	±63.5 mm	±2.50"
VERTICAL WORKING RANGE	+70.0 mm	+2.75"
	③ -31.7 mm	-1.25"
WEIGHT	5.0 Kg	11.0 LBS
MAXIMUM SPEED	270 M/MIN	900 FT/MIN
MAXIMUM CURRENT RATING	200A	200A
MAXIMUM CONTINUOUS WORKING TEMPERATURE	54 °C	130 °F
MINIMUM CONTINUOUS WORKING TEMPERATURE	-40 °C	-40 °F
MOUNTING SQUARE BAR SIZE	25.4 mm	1.00"
CABLE SIZE (EXTRA FLEXIBLE)	50 mm <sup>2</sup>	#2 AWG
MAXIMUM SHOE WEAR	5.3 mm	.21"

③	7	XA-592665	SCREW SET M10-1.5 X 12 EXT TIP SST		2	PC
③	6	XA-07735	SCREW 10-32 X .75 SELF-TAP SST		2	PC
	5	XA-591115	LABEL ETL FOR 200A SL2 COLL HARLAN		1	PC
	4	XA-590062	KIT SL2 GROUND INDICATOR/DEFLECTOR	①	2	PC
	3	XA-SL2C-200T-0M	COLLECTOR 200A SL2 TANDEM		1	PC
③	2	XA-589951	CLAMP CBL 7/16 IN ID X 1/2 IN W		2	PC
	1	XA-595421	CABLE 2AWG 1C 600V 1.4M LG		2	PC
	ITEM	MATERIAL NO. 2	DESCRIPTION	COMMENTS	QTY.	UNIT

STATUS: RELEASED		DESCRIPTION: COLLECTOR SL2 200A TDM GND 1M	
ER NO: ECO-28559	UNLESS OTHERWISE SPECIFIED	PROPRIETARY AND CONFIDENTIAL	
ER DATE: 01/28/2021	INTERPRET GEOMETRIC TOLERANCING	This drawing and the information shown constitute trade secret and confidential property of Conductix-Wipac, Inc. It is subject to recall, and is loaned for use only in connection with the authorized manufacture or installation of Conductix, Inc. products, and on the condition that it will be treated as confidential and will not be disclosed, published or reproduced in whole or in part, or permitted to be viewed or used by any other party, without specific written permission. Receipt and use of the drawing and information constitutes acceptance and agreement to the above.	
ER ENGR: J NEUMANN	PER: ASME Y14.5	10102 F Street Omaha, NE 68127 800-521-4888	
ER APPR: R FROST	PRIMARY UNITS ARE IN MM KG SECONDS	MATERIAL NO. 2: XA-SL2C-200TG-1M	
DRAWN: K COCHRAN	SECONDARY UNITS IN INCHES LB SECONDS	3	
APPR: K EASTMAN	TOLERANCES ARE AS FOLLOWS	WEIGHT(REF): 3.41 KG	
	DECIMAL:	MATL:	
	>1 <40 ±0.10	SCALE: 1:3	
	>40 <140 ±0.15	SHEET 1 OF 1	
	>140 <300 ±0.20		
	>300 <1000 ±0.50		
	ANG: ±1°		
	THREAD CLASS: 6G EXTERNAL / 6H INTERNAL		
	ALL DIMENSIONS GREATER THAN 100MM HAVE A TOLERANCE OF ±.2MM UNLESS OTHERWISE SPECIFIED		