

NOTES:

- ① TORQUE TO 2.83 N-M (25 IN-LBS).
- ② LOOSE PACK THE CONNECTOR.
- ③③ REMOVE ETL STICKER FROM COLLECTOR, IF PRESENT, AND REPLACE WITH ETL STICKER IN BOM.

INSTALLATION NOTES:

- ④ TORQUE TO 33.9 N-M (300 IN-LB)

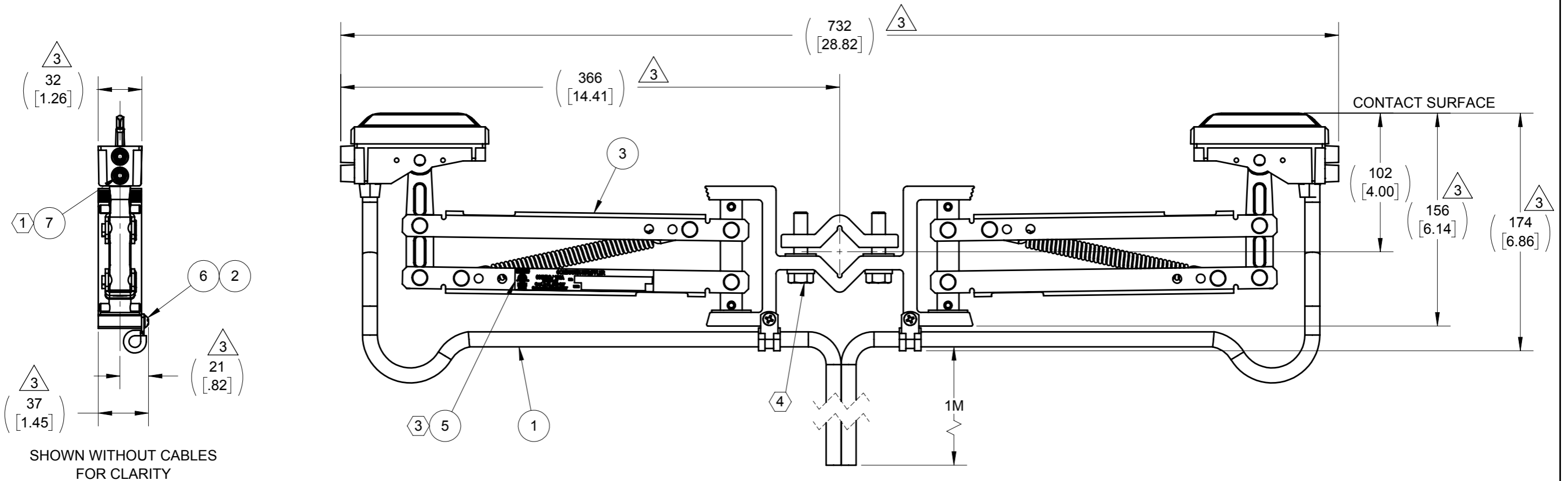

SPECIFICATIONS

COLLECTOR SETTING HEIGHT	102.0 mm	4.00"
CONTACT FORCE AT SETTING HEIGHT	20-36 N	4.5-8.0 LBS
LATERAL WORKING RANGE	±63.5 mm	±2.50"
VERTICAL WORKING RANGE	+70.0 mm	+2.75"
	③ -31.7 mm	-1.25"
WEIGHT	3.8 Kg	8.4 LBS
MAXIMUM SPEED	270 M/MIN	900 FT/MIN
MAXIMUM CURRENT RATING	100A	100A
MAXIMUM CONTINUOUS WORKING TEMPERATURE	54 °C	130 °F
MINIMUM CONTINUOUS WORKING TEMPERATURE	-40 °C	-40 °F
MOUNTING SQUARE BAR SIZE	25.4 mm	1.00"
CABLE SIZE (EXTRA FLEXIBLE)	34 mm ²	#4 AWG
MAXIMUM SHOE WEAR	5.3 mm	.21"

③	7	XA-592664	SCREW SET M8-1.25 X 10 EXT TIP SST		2	PC
③	6	XA-07735	SCREW 10-32 X .75 SELF-TAP SST		2	PC
	5	XA-591113	LABEL ETL FOR 100A SL2 COLL HARLAN		1	PC
	4	XA-589312	CONNECTOR 3 COND. MULTI-TAP 14-2/0 AWG	②	1	PC
	3	XA-SL2C-100T-0M	COLLECTOR 100A SL2 TANDEM		1	PC
	2	XA-589191	CLAMP CBL 3/8 IN ID X 1/2 IN W		2	PC
	1	XA-595374	CABLE 4AWG 1C 600V 1.37M LG		2	PC
	ITEM	MATERIAL NO. 2	DESCRIPTION	COMMENTS	QTY.	UNIT

STATUS: RELEASED		DESCRIPTION: COLLECTOR SL2 100A TDM PH W/TERM 1M	
ER NO: ECO-28559	UNLESS OTHERWISE SPECIFIED	PROPRIETARY AND CONFIDENTIAL	
ER DATE: 02/01/2021	INTERPRET GEOMETRIC TOLERANCING	This drawing and the information shown constitute trade secret and confidential property of Conductix-Wampler, Inc. It is subject to recall, and is loaned for use only in connection with the authorized manufacture or installation of Conductix, Inc. products, and on the condition that it will be treated as confidential and will not be disclosed, published or reproduced in whole or in part, or permitted to be viewed or used by any other party, without specific written permission. Receipt and use of the drawing and information constitutes acceptance and agreement to the above.	
ER ENGR: J NEUMANN	PER: ASME Y14.5		
ER APPR: R FROST	PRIMARY UNITS ARE IN MM KG SECONDS SECONDARY UNITS IN INCHES LB SECONDS TOLERANCES ARE AS FOLLOWS		
DRAWN: K COCHRAN	DECIMAL:	MATERIAL NO. 2: XA-SL2C-100TPY-1M	
APPR: K EASTMAN	>1: <40 +/- 0.10 >40: <140 +/- 0.15 >140: <300 +/- 0.20 >300: <1000 +/- 0.50 ANG: ± 1° THREAD CLASS: 6G EXTERNAL / 6H INTERNAL ALL DIMENSIONS GREATER THAN 100MM HAVE A TOLERANCE OF ± 2MM UNLESS OTHERWISE SPECIFIED	SIZE A3	SCALE: 1:3
		WEIGHT(REF): 8.62 LB	SHEET 1 of 1

